



**Features**

- Compact, Slim-Profile Design
- LED Indicator Enables Monitoring Operation
- Zero Cross For a Wide Range of Applications
- Built-in Snubber, Effectively Absorbs External Surge
- Protective Cover For Greater Safety
- Surface Mounting & DIN Rail Mounting with Heat Sin
- 1 Year Warranty

**INPUT SPECIFICATION**

Rated Voltage	5 to 24 VDC
Operating Voltage	4 to 32 VDC
Impedence	7mA max

**OUTPUT SPECIFICATION**

Rated load voltage	24 to 480 VAC		
Load voltage range	19 to 480 VAC		
Load current	MODEL	With heat sink	Without heat sink
	SRDA-16	0.1 to 16A (at 40°C)	0.1 to 3A (at 40°C)
	SRDA-25	0.1 to 25A (at 40°C)	0.1 to 4A (at 40°C)
SRDA-40	0.1 to 40A (at 40°C)	0.1 to 6A (at 40°C)	
VDRM, VCEO Reference value	600 V (VDRM)		
Inrush current	SRDA-16	150 A (60 Hz, 1 cycle)	
	SRDA-25	220 A (60 Hz, 1 cycle)	
	SRDA-40	440 A (60 Hz, 1 cycle)	

**CHARACTERISTICS**

Operation Time	1/2 of load power source cycle + 1 ms max.
Release Time	1/2 of load power source cycle + 1 ms max.
Output ON Voltage Drop	1.6V (RMS) max
Leakage Current	5 mA max. (at 100 VAC)
	10 mA max. (at 200 VAC)
Insulation resistance	100 MΩ min. (at 500 VDC)
Vibration resistance	Destruction: 10 to 55 to 10 Hz, 0.75-mm single amplitude (1.5-mm double amplitude)
Shock resistance	Destruction: 1,000 m/s <sup>2</sup>
Ambient temperature	Operating: -30°C to 80°C (with no icing or condensation)
	Storage: -30°C to 100°C (with no icing or condensation)
Ambient humidity	Operating: 45% to 85%

**OTHER SPECIFICATION**

Weight	0.75kg
Dimension (L*W*H)	57*42*28.2 mm

**ORDER CODE**

MODEL	INPUT VOLTAGE	OUTPUT VOLTAGE	RATED CURRENT
SRDA16	DC	AC	16A
SRDA25	DC	AC	25A
SRDA40	DC	AC	40A

**TERMINAL ARRANGEMENT**

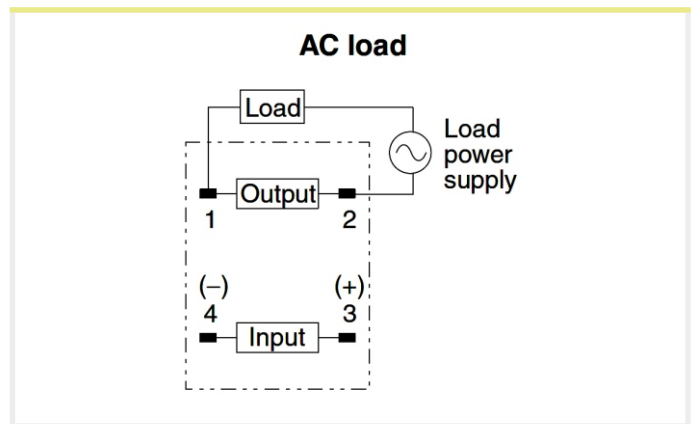

**DIMENSIONS**

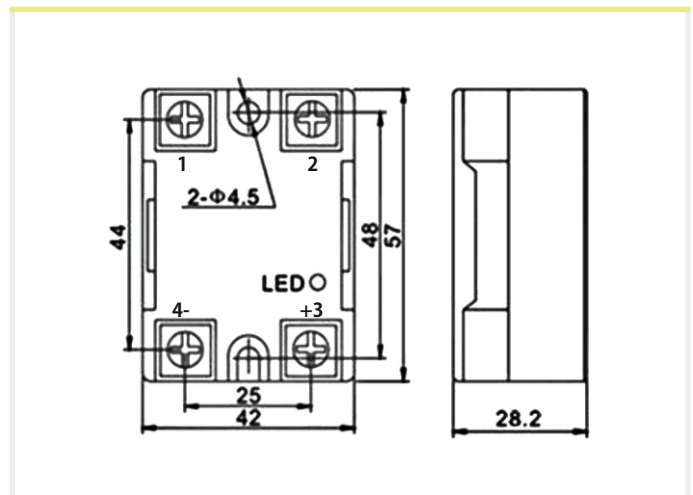

**HEATSINK RECOMMENDATIONS**

- We recommend that solid state relay modules be mounted to a heatsink sufficient to maintain the module's base temperature at less than 85°C under worst case ambient temperature and load conditions.
- The heatsink mounting surface should be a smooth (30-40 micro-inch finish), flat (30-40 micro-inch flatness across mating area), un-painted surface which is clean and free of oxidation.
- An even coating of thermal compound (Dow Corning DC340 or equivalent) should be applied to both the heatsink and module mounting surfaces and spread to a uniform depth of .002" to eliminate all air pockets.
- The module should be mounted to the heatsink using two M3 screws.