



**Features**

- PROTECTION : Short-circuit, Surge Absorber, Reverse connection
- Red Led Display Can Detect Sensor Work Status
- Easy To Set Up And Adjust Distance
- Waterproof, Anti Oil, Temperature And Other Advantages
- IP67 Protection Structure (IEC Specification)
- 1 Year Warranty



**GENERAL CHARACTERISTICS**

PARAMETERS	MOUNTING	AC - 2 Wire
Detecting Distance	NON FLUSH	2mm ± 10%
Frequency (Hz)		20Hz
Movement Differential	Max. 10% of detecting distance	
Standard Detected Target	Iron 8x8x1mm	

**ORDER CODE**

MODEL(Ø8mm)	TYPE	OUTPUT	MOUNTING	RANGE
CMA8-2-O	AC	NO	NONFLUSH	2mm
CMA8-2-C		NC		

**OPERATING CHARACTERISTICS**

Supply Voltage (V)	90-250VAC
Current Consumption (mA)	2.2mA max
Load Current (mA)	300mA max
Voltage Drop (Vp)	10V max

**DIMENSIONS**

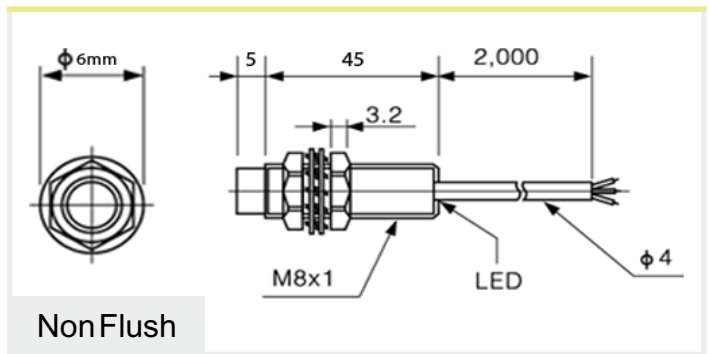

**ENVIRONMENT**

Operating Temperature	-25°C to + 70°C (non freezing condition)
Ambient Humidity	35% to 95% RH
Insulation Resistance	Min 50MΩ/500VDC
Dielectric Strength	1500VAC 50/60Hz for 1 minute

**OTHER CHARACTERISTICS**

Indicator	Operating	Red LED
Material	Case	BRASS
	Detecting surface	ABS
Connection Mode	2M lead wire type	
Protection Grade	IP67 (IEC Specification)	
Authentication	CE	

**PROTECTION & SECURITY**

Protection Circuit	Reverse Polarity Protection, Surge Absorber, Short Circuit Protection
Vibration	1mm amplitude at 10 ~ 55Hz Frequency for 120 min each in X, Y, Z Directions
Shock	500m/s <sup>2</sup> (50G) for 3 times in X, Y, Z Directions